

## QUICK SET CASEMAKER

### Workable formats and overall performances



## CASEMAKER HGL 924

Revision	Description	Date	Reviewed by
1.5	Updated version	28/04/2023	G.Gubitta
1.6	Updated version	18/09/2024	L.Fuoglio
1.7	Updated version	28/03/2025	L.Fuoglio
1.8	Updated version	02/03/2026	L.Fuoglio
1.9	Updated version	22/04/2026	L.Fuoglio

## Workable formats

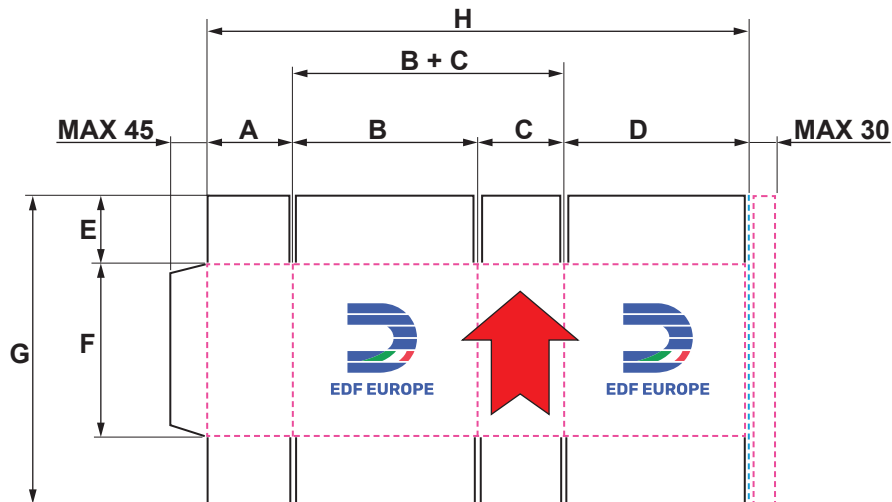

SIDES	DEFINITION	Min	Max
H	A+B+C+D (mm)	440	2.400
G	Inserted sheet length (mm)	260	900
G	Skip feed (mm)	/	1.200
E	Slots length from slotter (mm)	0	350
F	Height of box from slotter (mm)	60*	750*
G	Die-cut sheet length (mm)	260	860
A = C	Box short side from slotter (mm)	110	1.090
B = D	Box long side from slotter (mm)	110	1.090
A = C	Short side of the box in fold (mm)	110	1.030
B = D	Long side of the box in fold (mm)	190	1.090
B + C	Distance between the folding axes (mm)	300**	1.200
	Open box passage in fold (mm)	560	1.700

\* With "F" > 640 mm some blades need to be removed

\*\* Use **single wall** corrugated cardboard only

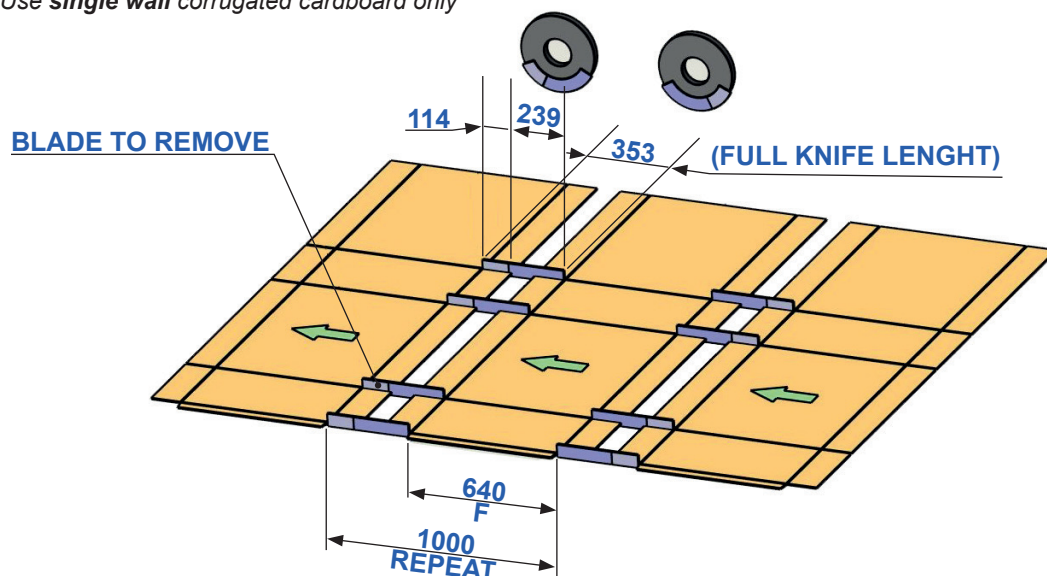

## General characteristics

Theoretical roll circumference:	<b>1.000 mm</b>
Machine speed:	<b>min 1.000 - max 18.000 sheets/h, max 300 mt/min</b>
Minimum sheet size:	<b>500 x 260 mm</b>
Maximum sheet size:	<b>2.475 x 900 mm (2.475 x 1.200 mm with skep feed)</b>
Max print area:	<b>2.400 x 900 mm</b>
Board thickness:	<b>1 - 10 mm</b>
Slotting blades thickness:	<b>7,5 mm (option 10 mm)</b>
Main shafts driven Brushless Servomotors and drives, connected with low backlash planetary gearboxes	
Approximate total power used around 200 kW (for 4 printing units)	
Centralized operator terminal for order entry and general control of the entire line	
Local HMI control panels on each single group	
Integrated soundproofing guard	

## Indicative overall performances\*:

Introduction register between lead edge and the 1st printing unit	<b>+/- 1,0 mm</b>
Print register between the 1st and 4th printing unit	<b>+/- 0,5 mm</b>
Print register between the 1st and 5th printing unit	<b>+/- 0,6 mm</b>
Print register between the 1st and 6th printing unit	<b>+/- 0,7 mm</b>
Slot cutting register between last print and the slot	<b>+/- 0,5 mm</b>
RDC register between the last print and the die	<b>+/- 0,7 mm</b>

FTB (FishTail glue tab side) with single and double corrugation	<b>+/- 1,0 mm</b>
FTR (FishTail trim side) with single and double corrugation	<b>+/- 1,0 mm</b>
LG (Lead edge Gap) single corrugation	<b>+/- 3,0 mm</b>
LG (Lead edge Gap) double corrugation	<b>+/- 4,0 mm</b>
TG (Trail Gap) single corrugation	<b>+/- 3,0 mm</b>
TG (Trail Gap) double corrugation	<b>+/- 4,0 mm</b>

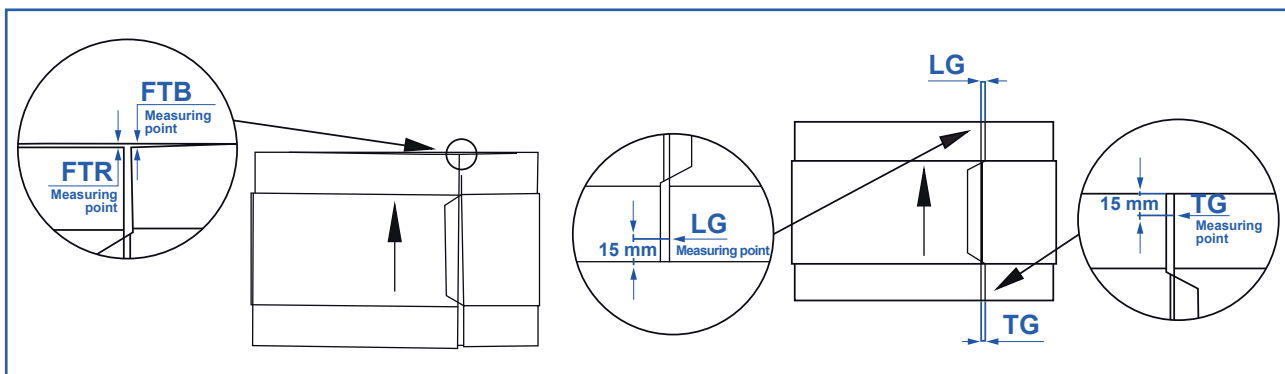

\* The values reported above are to be considered purely indicative. Guaranteed performance levels will be defined exclusively during the **commissioning** phase, at which time at least five (5) packaging types will be agreed upon between EDF and the end user. A specific technical data sheet will be drawn up for each packaging type, detailing the actual achievable performance and any potential limitations. Consequently, this document does not constitute a binding commitment in the absence of the aforementioned technical agreement.